

INFLUENCE OF STREAM SWIRLING ON HEAT TRANSFER IN THE CYLINDRICAL
SECTION OF THE PRENOZZLE VOLUME OF A MODEL CHAMBER

F. I. Sharafutdinov, A. I. Mironov,
and V. K. Shchukin

UDC 536.532.4

The results are presented of an experimental investigation of the heat transfer of a swirled stream in the cylindrical part of the chamber when swirlers with straight vanes are used.

The swirling of a gas stream moving in the prenozzle volume of a chamber leads to the development of a nonuniform field of mass forces which alter the structure and conditions of interaction of the stream with the chamber walls. All this leads to a change both in the overall level of heat exchange and in the distribution of local heat-transfer coefficients along the channel.

There are presently a considerable number of investigations devoted to the study of the heat transfer of a swirling stream in the initial section of a pipe. In [1] an attempt is made to generalize them on the basis of the theory of local modeling using an integral parameter characterizing the intensity of stream swirling in the initial cross section of the channel. The dependence proposed by the author allows one to determine the correction Ψ_φ to the standard law of heat exchange due to the stream swirling for the initial section of the pipe from the calculated value ϕ_{enc} of this parameter. This dependence is in satisfactory agreement with test data on the use of swirlers, for which the calculated value of the swirling parameter ϕ_{enc} differs slightly from the actual (experimental) value.

For vane swirlers with straight vanes, not having an axial clearance in the flow-through part, the calculated value of the swirling intensity parameter (computed using the equation presented in [2]) can differ considerably from its actual value. For example, for a swirler with a relative diameter of the central body $\bar{d}_{cb} = 0.46$ and a vane setting angle $\varphi_c = 45^\circ$ the calculated value of the parameter is $\phi_{enc} = 0.7$ while the experimental value is $\phi_{en} = 1.3$ [3]. When such swirlers are used, therefore, an estimate of the heat transfer on the basis of the dependence proposed in [1] does not provide sufficient accuracy. Moreover, data on the heat transfer of a swirled stream under the conditions of diaphragming, corresponding to an engine chamber, are absent from the literature. Below we present the results of an experimental investigation of heat transfer to the walls of the cylindrical part of a chamber with stream swirling by vane swirlers not having an axial clearance in the flow-through part.

The heat-transfer coefficients were determined by the gradient method [4] with a numerical estimate of the temperature fields in the wall of the experimental section under non-steady conditions of occurrence of the process of heat conduction. The experimental section (Fig. 1a) consisted of a thick-walled pipe of 1Kh18N9T steel. The inner diameter of the pipe was $d = 106.8$ mm, the length 180 mm, and the wall thickness 15 mm. Thirty Nichrome-Constantan thermocouples were embedded in the inner, outer, and end surfaces. The temperature distribution on these surfaces measured in the course of the experiment was used as the boundary condition in estimating the nonsteady temperature field in the wall of the experimental section.

Swirlers with straight vanes and with a relative diameter $\bar{d}_{cb} = 0.131$ of the central body and a constant angle φ_c of vane setting over the height were used for the stream swirling. The swirlers had 12 vanes each. To eliminate the axial clearance of the flow-through part the width of the vanes was increased toward the periphery. To decrease the axial dimensions in the swirler with $\varphi_c = 15^\circ$ we installed 12 additional vanes, which were fastened with brackets to the frame of the swirler, between the main vanes. The swirlers were mounted in front of the experimental section by a distance $L_0 = 0.135$ m. To model the hydrodynamic

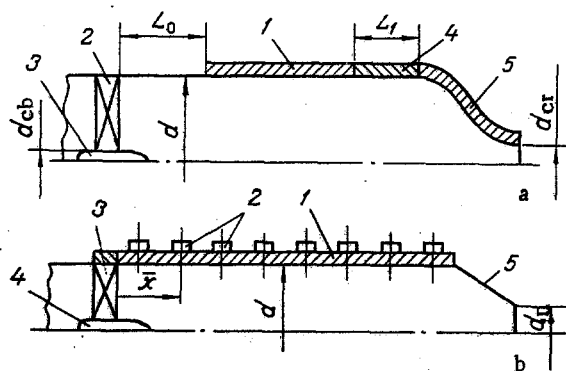

Fig. 1. Diagram of units of the experimental section for the investigation of: a) heat transfer: 1) experimental section; 2) swirler; 3) central body of swirler; 4) adapter; 5) nozzle section; b) structure of swirler stream: 1) experimental section; 2) measurement bands; 3) swirler; 4) central body of swirler; 5) converging section.

conditions corresponding to the prenozzle volume of an engine chamber we placed a cylindrical adapter with a length $L_1 = 0.114$ m and a nozzle section [5] profiled along arcs of circles at the exit from the experimental section. The diameter of the critical cross section of the nozzle was $d_{cr} = 25$ mm ($m = 0.055$).

The experimental installation and the method of performing the tests are described in [5]. The experiments were conducted in the following range of the operating parameters: pressure in chamber $P_C = 2.8-6.7$ bar; stagnation temperature $T_f^* = 470-600^\circ\text{K}$; Reynolds number Re , determined from the average gas velocity w_{av} and the diameter d , varied in the range of $(0.8-2.4) \cdot 10^5$.

The test data were treated and generalized by the local modeling method [6]. As a result of the treatment we found the correction Ψ_φ to the standard law of heat exchange for a plate caused by the swirling:

$$\Psi_\varphi = \frac{1}{\Psi_t} \left(\frac{St}{St_0} \right)_{Re_t^*} \quad (1)$$

Here Ψ_t is the correction to the standard law of heat exchange due to the nonisothermy. The quantity Ψ_t was determined with the help of the equation

$$\Psi_t = 4 / \left(\sqrt{\frac{T_w}{T_f^*} + 1} \right)^2 \quad (2)$$

For each regime the following quantities were found in 16 cross sections of the experimental section:

$$St = q_w / c_p \rho_0 w_{x0} (T_f^* - T_w); \quad (3)$$

$$Re_t^* = \rho_0 w_{x0} \delta_t^* / \eta_w = \int_0^x q_w(x) dx / c_p \eta_w (T_f^* - T_w); \quad (4)$$

$$St_0 = 0.0128 / Re_t^{*0.25} Pr^{0.75} \quad (5)$$

The quantity $\rho_0 w_{x0}$ and the actual value of the parameter ϕ_{en} of stream swirling intensity were determined experimentally. For this we built an experimental section (Fig. 1b) which made it possible to measure the parameters of the gas at different points along the radius in eight cross sections of the flow-through part. The inner diameter of the experimental section was $d = 106.8$ mm and the length was 4.4 diameters. Swirlers were mounted at the entrance to the experimental section while nozzles having a minimum cross section with a diameter $d_n = 31$ mm ($m = 0.085$) and $d_n = 60$ mm ($m = 0.219$) were mounted at the exit.

A three-channel probe fastened to a coordinating device, which made it possible to move the receiver in height and to rotate it about its axis, was used as the pressure detector.

The experiments were performed in the range of Reynolds numbers $Re = (0.8-1.7) \cdot 10^5$. In the course of the experiments we measured the air flow rate, the static pressure, the velocity head, and the direction of the velocity vector at assigned points. From these data we found the gas velocity w , its axial and circular components w_x and w_φ , the radial variation of the stream swirling, and the swirling intensity parameter ϕ in the cross section under consideration.

The quantity Φ was determined from the equation

$$\Phi = \frac{1}{R_c} \frac{\int_{r_{cb}}^R \rho \omega_x \omega_\varphi r^2 dr}{\int_{r_{cb}}^R \rho \omega_x^2 r dr}.$$

Here $r_{cb} = d_{cb}/2$ and $R = d/2$.

A generalization of the test data obtained on the structure of the swirled flow and of data available in the literature [3, 7] for vane swirlers with $\varphi_c = \text{const}$ and not having an axial clearance in the flow-through part allows us to write the following equations for the swirling intensity parameter Φ_{en} at the exit from the swirler and for the maximum value of the axial component of the mass velocity $\rho_0 \omega_{x0}$ in the boundary zone of the initial section of a pipe with a length of two to four diameters:

$$\Phi_{en} = 1.66 (\text{tg } \varphi_c)^{1.07} (d_{cb}/d)^{0.36} \quad (6)$$

[Eq. (6) was obtained for $Re = (0.8-1.7) \cdot 10^5$, $m = 0.084-1$, $\bar{d}_{cb} = 0.131-0.46$, and $\varphi_c = 15-60^\circ$];

$$\rho_0 \omega_{x0} / \rho \omega_{av} = [1 + 0.27 (\text{tg } \varphi_c)^{0.78}] (0.94 + 0.06 m^2) \quad (7)$$

[Eq. (7) was obtained for $Re = (0.8-1.7) \cdot 10^5$, $m = 0.084-1$, $\bar{d}_{cb} = 0.131$, and $\varphi_c = 15-45^\circ$];

$$\rho_0 \omega_{x0} / \rho \omega_{av} = 1 + 0.72 (\text{tg } \varphi_c)^{0.78} (d_{cb}/d)^{0.49}. \quad (8)$$

Equation (8) was obtained for $Re = (0.8-1.5) \cdot 10^5$, $m = 1$, $\bar{d}_{cb} = 0.131-0.46$, and $\varphi_c = 15-60^\circ$.

As is seen, using Eq. (6) one can estimate the actual value of the swirling intensity parameter Φ_{en} for swirlers with different \bar{d}_{cb} and φ_c both under conditions of diaphragming and without diaphragming.

Using (7) one can determine the value of $\rho_0 \omega_{x0}$ in the initial section of a pipe under conditions of diaphragming when swirlers with $\bar{d}_{cb} = 0.131$ are used.

Using (8) one can determine the value of $\rho_0 \omega_{x0}$ when swirlers with different \bar{d}_{cb} are used, but only under conditions of the absence of diaphragming.

It should be kept in mind that Eqs. (6)-(8) are only valid for swirlers with straight vanes not having an axial clearance in the flow-through section. In the general case (for swirlers with profiled vanes and an axial clearance in the flow-through section) when determining Φ_{en} and $\rho_0 \omega_{x0}$ one must also allow for the law of vane profiling over the height and the influence of the Reynolds number.

Along with the study of the structure of the gas flow in the immediate vicinity of the swirler, we conducted a series of experiments with axial air flow (swirlers absent, length of preconnected thermally insulated section $L_0 = 2.91$ m) to test the reliability of the determination of the local coefficients of heat transfer by the gradient method. The test results were compared (Fig. 2) with the law of heat exchange for the initial section of a pipe:

$$St_0 = 0.0143 / Re_t^{*0.25} Pr^{0.75}. \quad (9)$$

As seen from the figure, the test points, with allowance for the correction Ψ_t for non-isothermy and Ψ_{bl} for the nonsimultaneity of the development of the dynamic and thermal boundary layers, are grouped around the dependence (9). The deviation of the test points from the line determined by Eq. (9) is $\pm 10\%$.

The correction Ψ_{bl} was found from the equation [6]

$$\Psi_{bl} = \left(\frac{L - L_0}{L} \right)^{0.086}.$$

The test data on heat transfer in the presence of swirling were generalized in the form

$$\Psi_\varphi - 1 = f(\Phi_{en}). \quad (10)$$

Here Φ_{en} is the actual value of the parameter of stream-swirling intensity at the exit from the swirler. Its value was found from Eq. (6).

The results of the treatment and generalization of the test data for all the swirlers are presented in Fig. 3. It is seen that the test points are grouped rather tightly around the line determined by the equation

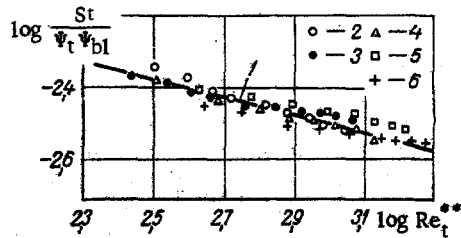

Fig. 2

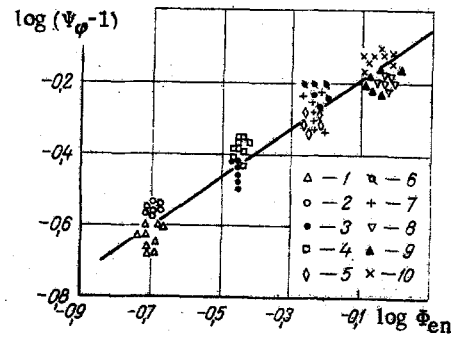

Fig. 3

Fig. 2. Comparison of test data on heat transfer during axial flow with the law of heat exchange in the initial section of a pipe: 1) $St_0 = (0.0143)/(Re_t^{**0.25} Pr^{0.75})$; 2) $Re = 10^5$; 3) $1.11 \cdot 10^5$; 4) $1.32 \cdot 10^5$; 5) $1.89 \cdot 10^5$; 6) $2.27 \cdot 10^5$.

Fig. 3. Results of generalization of test data on heat transfer in the presence of stream swirling: $\varphi_c = 15^\circ$: 1) $Re = 10^5$; 2) $1.41 \cdot 10^5$; $\varphi_c = 25^\circ$: 3) $1.71 \cdot 10^5$; 4) $2.19 \cdot 10^5$; $\varphi_c = 35^\circ$: 5) $0.94 \cdot 10^5$; 6) $1.69 \cdot 10^5$; 7) $2.1 \cdot 10^5$; $\varphi_c = 45^\circ$: 8) 10^5 ; 9) $1.28 \cdot 10^5$; 10) $2.2 \cdot 10^5$.

$$\Psi_\varphi = 1 + 0.8 \Phi_{en}^{0.7} \quad (11)$$

Equation (11) was obtained for $Re = (0.8-2.2) \cdot 10^5$, $m = 0.055$, $\bar{d}_{cb} = 0.131$, and $\varphi_c = 15, 25, 35, \text{ and } 45^\circ$.

An analysis shows that the dependence (11) is in satisfactory agreement with the test data of [8], obtained for the initial section of a pipe using a swirler with straight vanes and with $\bar{d}_{cb} = 0.46$, if the correction Ψ_φ to the standard law of heat exchange obtained in [8] is corrected with allowance for the determination of the mass velocity $\rho_0 w_{x0}$ of the gas.

The dependence (11) obtained as a result of the generalization of the test data allow us to solve the integral energy equation, which retains its form for swirled flow [1]:

$$\frac{dRe_t^{**}}{dx} + \frac{Re_t^{**}}{\Delta T} \frac{d(\Delta T)}{dx} = St Re_L \quad (12)$$

Here $Re_L = \rho_0 w_{x0} d / \eta_{00}$; $\Delta T = T_f^* - T_w$; $\bar{x} = x/d$.

The Stanton number entering into Eq. (12) is determined by the law of heat exchange for swirled flow. This law, with allowance for the determination of the Reynolds number Re_t^{**} from the viscosity of the gas at the wall temperature, has the form

$$St = \frac{B}{2} \left(\frac{\eta_w}{\eta_{00}} \right)^m Re_t^{**m} Pr^{-n} \Psi_t \Psi_\varphi \quad (13)$$

On the basis of a joint solution of Eqs. (12) and (13) we can write the following equation for a calculated estimate of the heat transfer in the initial section of a pipe with an arbitrary law of variation of the wall temperature along its length:

$$St = \frac{\alpha}{c_p \rho_0 w_{x0}} = \left(\Delta T \frac{\eta_w}{\eta_{00}} \right)^m \left[\frac{B}{2 Pr^n} (1 + 0.8 \Phi_{en}^{0.7}) \right]^{\frac{1}{1+m}} \left[(1+m) \int_0^{\bar{x}} Re_L \left(\frac{\eta_w}{\eta_{00}} \right)^m (\Delta T)^{1+m} \Psi_t dx \right]^{-\frac{m}{1+m}} \Psi_t \quad (14)$$

The constants B, m, and n entering into (14) depend on Re_t^{**} [6]. For $Re_t^{**} < 10^4$ their values are 0.0256, 0.25, and 0.75, respectively.

Thus, when the law of variation of the wall temperature along the pipe length is known one can use the dependences (6), (7), and (14) to approximately estimate the heat transfer of a swirled stream in the initial section of the pipe under conditions of diaphragming (in the cylindrical part of the prenozzle volume of an engine chamber) when a vane swirler is used which does not have an axial clearance in the flow-through part and with $\bar{d}_{cb} = 0.131$.

Using the dependences (6), (8), and (14) one can estimate the heat transfer in the initial section of a pipe without diaphragming when swirlers with different \bar{d}_{cb} are used.

NOTATION

d, d_{cb}, d_n , diameters of cylindrical part of chamber, of central body of swirler, and of minimum nozzle cross section; L_0, L , length of preconnected, thermally insulated section and distance from start of development of the dynamic boundary layer to the cross section under consideration; $\Phi, \Phi_{enc}, \Phi_{en}$, value of the swirling intensity parameter in the cross section under consideration and its calculated and actual values at the exit from the swirler (at the entrance to the channel); P_c, c_p, T_f^* , pressure in the chamber and heat capacity and stagnation temperature of the gas; η_w, η_{o0} , dynamic coefficient of viscosity of the gas at the wall temperature T_w and at the stagnation temperature T_f^* ; $q_w(x)$, local density of heat flux to the wall in the cross section under consideration; w_{x0} , maximum value of axial component of gas velocity in the boundary zone; ρ_0 , gas density at the point where $w_x = w_{x0}$; Re_t^{**} , Reynolds number determined from the conditional thickness of energy loss δ_t^{**} ; $m = (d_n/d)^2$, degree of diaphragming; w_x, w_ϕ , axial and circular components of gas velocity; Re_L , Reynolds number determined from the maximum value of the mass velocity in the cross section under consideration; x , distance from initial cross section of channel to the cross section under consideration.

LITERATURE CITED

1. A. A. Khalatov, *Izv. Vyssh. Uchebn. Zaved., Aviats. Tekh.*, No. 1 (1977).
2. V. I. Goldobeev, V. K. Shchukin, A. A. Khalatov, and A. P. Yakshin, *Izv. Vyssh. Uchebn. Zaved., Aviats. Tekh.*, No. 4 (1973).
3. A. A. Khalatov, V. K. Shchukin, and V. G. Letyagin, *Inzh.-Fiz. Zh.*, **33**, No. 2 (1977).
4. V. K. Shchukin, Heat Exchange and Hydrodynamics of Internal Flows in Mass Force Fields [in Russian], Mashinostroenie, Moscow (1970).
5. V. K. Shchukin, A. I. Mironov, V. A. Filin, and F. I. Sharafutdinov, *Izv. Vyssh. Uchebn. Zaved., Aviats. Tekh.*, No. 3 (1975).
6. S. S. Kutateladze and A. I. Leont'ev, Heat and Mass Exchange and Friction in a Turbulent Boundary Layer [in Russian], Energiya (1972).
7. Yu. A. Pustovoi, "Turbulent swirled streams in the axisymmetric channels of aircraft engines," Candidate's Dissertation, Kazan (1976).
8. V. I. Goldobeev, V. K. Shchukin, and A. A. Khalatov, *Tr. Kazan. Aviats. Inst.*, No. 154 (1973).

KINETICS OF THE PRECIPITATION OF A SUBSTANCE FROM A GAS MIXTURE

V. V. Levdanskii

UDC 536.423.4

The kinetics of the process of precipitation of a substance from a gas mixture is investigated. Problems connected with the capture of molecules of the noncondensing component by the growing layer of condensate of the readily condensing gas are discussed.

The problem of the condensation of multicomponent gas mixtures plays an important role in many technological processes (the deposit of layers of substances of an assigned composition, the separation of gas mixtures, the removal of gases from vacuum systems, etc.).

The phenomenon of cryocapture, the essence of which consists in the absorption of molecules of a gas which does not condense at the given temperature of the cryopanel during the precipitation of a readily condensing gas under conditions of their simultaneous supply [1], is widely used in cryogenic technology. Generally speaking, such absorption can occur in any process of precipitation of a substance from a multicomponent mixture (the presence of cryogenic temperatures is not an obligatory condition). A theory of the given process must be constructed on the basis of a molecular-kinetic approach. But the kinetics of the conden-

A. V. Lykov Institute of Heat and Mass Exchange, Academy of Sciences of the Belorussian SSR, Minsk. Translated from *Inzhenerno-Fizicheskii Zhurnal*, Vol. 37, No. 4, pp. 602-608, October, 1979. Original article submitted November 29, 1978.